



IMP PUMPS[®]

Intelligent Motor Pumps

**ONE MICRO STEP
FOR A PUMP,
ONE GIANT LEAP IN
PUMPING TECHNOLOGY!**



**AVAILABLE
NOW!**

mce
**EXCELLENCE
AWARDS
WINNER
2026**

FMT MICRO



Follow us on LinkedIn:

www.imp-pumps.com

FMT MICRO



Features

IMPPUMPS®



FMT MOTOR

Integrates the most innovative IMP PUMPS motor technology



RECIRCULATION LOOP PUMP

Instant hot water supply eliminating the waiting time for hot water



COMPACT DESIGN

World's smallest pump in its class - fits almost anywhere!



PATENTED TOUCH TIMER

Set the timer with a simple swipe on the LED display



SAVING WATER

Saves up to 35.000 liters of water annually and reduces costs



ENHANCED HYGIENE

Regular recirculation prevents water stagnation, bad odors, and bacteria

Technical data

IMP PUMPS®

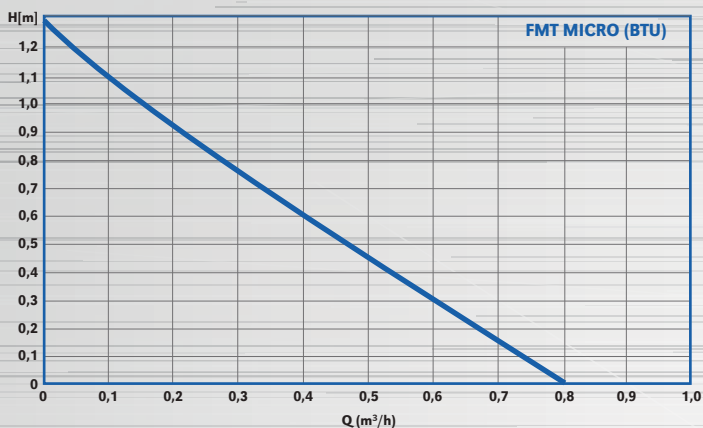

Technical specification

Diameter nominal, DN	15
Threaded connection	G 1/2"
Insulation class	F
Degree of protection	IP 44
Medium temperature	5 - 85°C
Ambient temperature	0 - 40°C

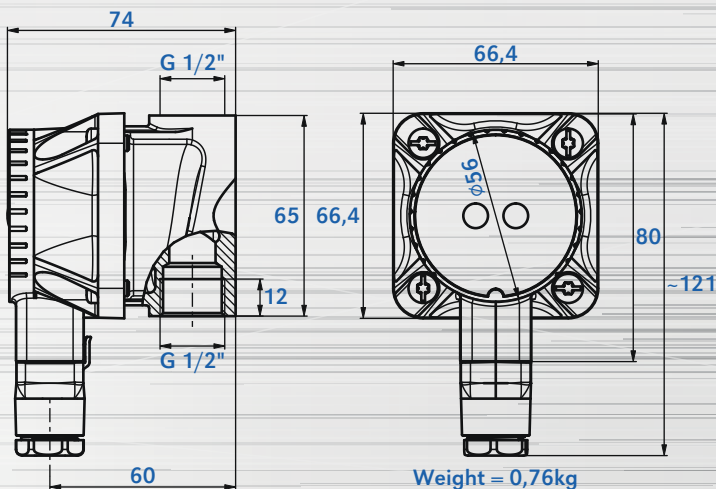

FMT MICRO



Four versions of FMT MICRO

IMP PUMPS®

FMT MICRO B
BASIC VERSION

FMT MICRO BT
with thermostat (20°C - 70°C)



FMT MICRO BU
with timer



FMT MICRO BTU
with thermostat (20°C - 70°C)
and timer



**ONE MICRO STEP FOR A PUMP,
ONE GIANT LEAP IN PUMPING TECHNOLOGY!**



IMP PUMPS®
Intelligent Motor Pumps

IMP PUMPS d.o.o.
Pod hrasti 28, 1218 Komenda
SLOVENIA

T: +386 1 28 06 400
E: info@imp-pumps.com
www.imp-pumps.com