

NMT NEO

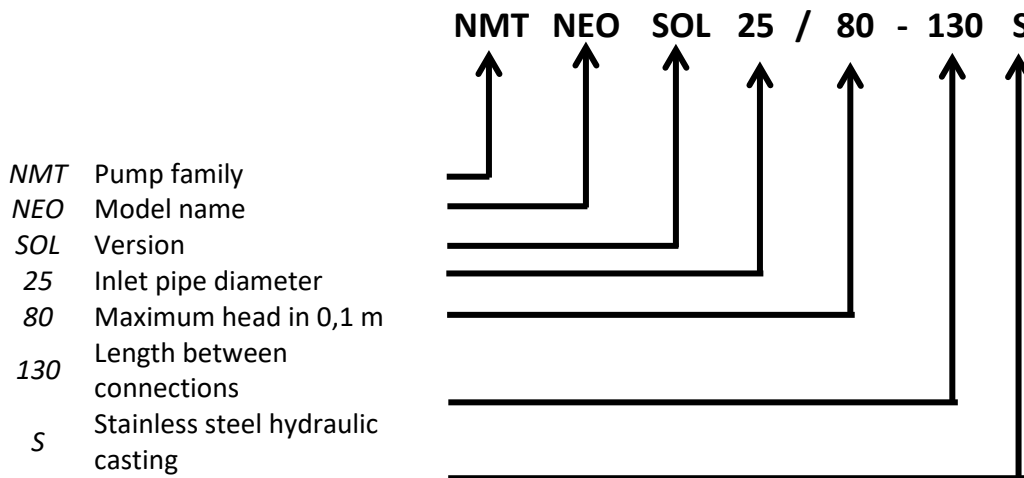

1 GENERAL INFORMATION

1.1 PUMP LABELING



1.2 STANDARDS

	EU directive	Harmonized standard
Compliance of the product with EU standards	Machinery 2006/42/EC;	EN 809;
	Low Voltage 2006/95/EC;	EN 60335-1; EN 60335-2-51;
	Electromagnetic compatibility (EMC) 2004/108/EC	EN 55014-1; EN 55014-2; EN 61000-3-2; EN 61000-3-3;
	Ecodesign Directive (2009/125/EC) Circulators: Commission Regulation No. 641/2009. EEI ≤ 0.23 (see pump name plate or datasheet)	EN 16297-1:2012; EN 16297-2:2012;

1.3 TECHNICAL SPECIFICATION OF PUMP

Pump	Maximum nominal pressure	Protection class	Insulation class	EEI	T _{maks ambient}	T _{min medium}	T _{maks medium}
NMT NEO XX/30	10 bar (1MPa)	IP 44	155 (F)	0,13	70 °C	-10 °C	110 °C
NMT NEO XX/40				0,14			
NMT NEO XX/50				0,16			
NMT NEO XX/60				0,17			
NMT NEO XX/70				0,18			
NMT NEO XX/80				0,18	25 °C	95 °C	
NMT NEO XX/85				0,18			
NMT NEO XX/90				0,18			
NMT NEO XX/100				0,18			
NMT NEO HF XX/100				0,2			
NMT NEO HF XX/120	0,2						
NMT NEO UHF XX/80	0,19						
NMT NEO UHF XX/120	0,2						

1.4 ELECTRICAL SPECIFICATION OF PUMP

Pump type	Rated voltage	P_{min} [W]	P_{maks} [W]	I_{min} [A]	I_{maks} [A]	RPM _{MIN}	RPM _{MAKS}
NMT NEO XX/30	230VAC ± 15%, 47-63Hz Pumps work with power at lower voltage ($P=I_{maks} * U$)	1	15	0,05	0,2	850	3400
NMT NEO XX/40			20		0,2	1000	4000
NMT NEO XX/50			28		0,3	1025	4100
NMT NEO XX/60			35		0,4	1200	4800
NMT NEO XX/70			40		0,4	1300	5200
NMT NEO XX/80			50		0,5	1400	5600
NMT NEO XX/85			60		0,6	1425	5700
NMT NEO XX/90			75		0,8	1450	5800
NMT NEO XX/100			90		0,9	1550	6200
NMT NEO HF XX/100			100		1,1	1575	6300
NMT NEO HF XX/120			160		0,8	1300	6700
NMT NEO UHF XX/80			145		1,1	1500	5900
NMT NEO UHF XX/120			160		1,3	1775	7100

1.5 ELECTRICAL CONNECTION

1.5.1 POWER CONNECTION

The electrical connection of the pump to the network must be done with TE Superseal connector. Pictures below show how the electrical connections are made.

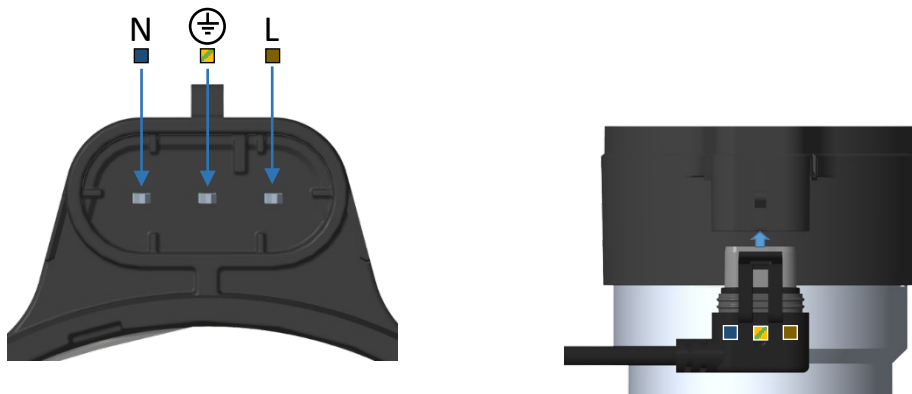

1.5.2 EXTERNAL SIGNAL CONNECTION

PWM signal is connected via TE Superseal-mini connector. Pictures below show how the electrical connections are made.

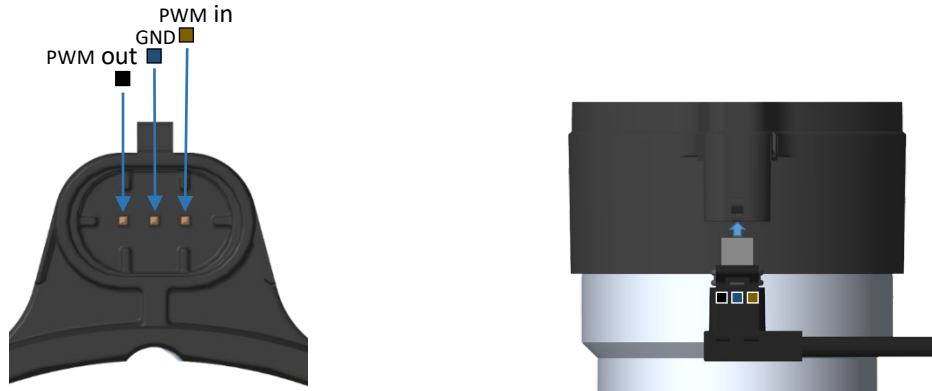





1.6 CONFIGURATION

	Code	Explanation
Type	NMT Neo	Standard pump with flow up to 5,5m ³ /h
	NMT Neo HF	Standard pump with flow up to 9m ³ /h
	NMT Neo UHF	Standard pump with flow up to 11m ³ /h
Control interface	(No label)	Auto mode 3 speed proportional pressure, 3 speed constant pressure, 3 speed constant speed,
	PWM	3 speed proportional pressure, 3 speed constant pressure, 3 speed constant speed, PWM Heating profile in constant speed, PWM Solar profile in constant speed PWM output
	Sol	PWM solar profile with constant speed and PWM output
	Heat	PWM heating profile with constant speed and PWM output
	Special version	L
Nominal diameter	15	R 1/2" / G1"
	20	R 3/4"
	25	R 1" / G1/2"
	32	R 1 1/4" / G 2"
	40	Flange
	50	Flange
Maximum head	XX	Without hydraulic casting
	40	4 m
	50	5 m
	60	6 m
	70	7 m
	80	8 m
	85	8,5m
	90	9 m
	100	10 m
	120	12 m
	130	Cast iron 130mm

Pump housing	180	Cast iron 180mm
	F220	Cast iron with flange 220mm
	F240	Cast iron with flange 240mm
	130S	Stainless steel 130mm
	180S	Stainless steel 180mm
	F220S	Stainless steel with flange 220mm
	F240S	Stainless steel with flange 240mm
	XXX	Without hydraulic casting
Orientation	D	Down(standard) - 0°
	U	Up - 180°
	L	Left - 270°
	R	Right - 90°
Start Up setting	AUO	Auto mode
	1PP	1 speed proportional pressure
	2PP	2 speed proportional pressure
	3PP	3 speed proportional pressure
	1CP	1 speed constant pressure
	2CP	2 speed constant pressure
	3CP	3 speed constant pressure
	1CC	1 speed constant speed
	2CC	2 speed constant speed
	3CC	3 speed constant speed
	HCC	PWM Heating profile in constant speed
	SCC	PWM Solar profile in constant speed
Manual	NO	Without
	PM	Picture manual
	WM	Written manual in all languages
	WA	Written manual in ENG, DEU, ITA
Insulation	IY	Insulation included
	IN	Insulation not included
Power cable	PCS050	Straight connector, cable length 50cm
	PCS100	Straight connector, cable length 100cm
	PCS150	Straight connector, cable length 150cm
	PCS200	Straight connector, cable length 200cm
	PCA050	Elbow connector, cable length 50cm
	PCA100	Elbow connector, cable length 100cm
	PCA150	Elbow connector, cable length 150cm
	PCA200	Elbow connector, cable length 200cm
External signal cable	DCS050	Straight connector, cable length 50cm
	DCS100	Straight connector, cable length 100cm
	DCS150	Straight connector, cable length 150cm
	DCS200	Straight connector, cable length 200cm
	DCA050	Elbow connector, cable length 50cm
	DCA100	Elbow connector, cable length 100cm
	DCA150	Elbow connector, cable length 150cm
	DCA200	Elbow connector, cable length 200cm

1.7 VERSIONS

1.7.1 NMT NEO

Display	Mode of operation	Pump curve
	Auto mode (blinking)	Non selectable
	Proportional pressure	
	Constant pressure	Third curve (orange) Second curve (green) First curve (blue)
	Constant speed	

1.7.2 NMT NEO PWM

Display	Mode of operation	Pump curve
	Proportional pressure	
	Constant pressure	Third level (orange) Second level (green) First level (blue)
	Constant speed	
	PWM heating profile - constant speed	Blinking PWM value PWM > 66% - orange 33% < PWM < 66% - green PWM < 33% - blue
	PWM solar profile - constant speed	

1.7.3 NMT NEO SOL/HEAT

Display	Mode of operation	Curve
	PWM Sol/Heat profile - constant speed	Blinking PWM value PWM > 66% - orange 33% < PWM < 66% - green PWM < 33% - blue

1.7.3.1 NMT NEO HEAT PWM RESPONSE

PWM input – heating profile	Pump response
≤5% or no signal	Maximum curve
>5% - ≤85%	Variable curve
>85% - ≤88%	Minimum curve
>88% - ≤93%	Hysteresis area
>93% - ≤100%	Standby

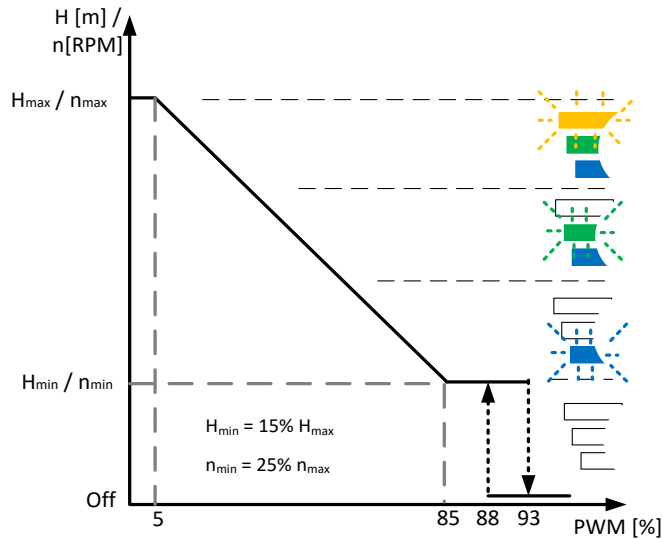

1.7.3.2 NMT NEO SOL PWM RESPONSE

PWM input – solar profile	Pump response
>95% - 100%	Maximum curve
>15% - ≤95%	Variable curve
>12% - ≤15%	Minimum curve
>7% - ≤12%	Hysteresis area
≤7% or no signal	Standby

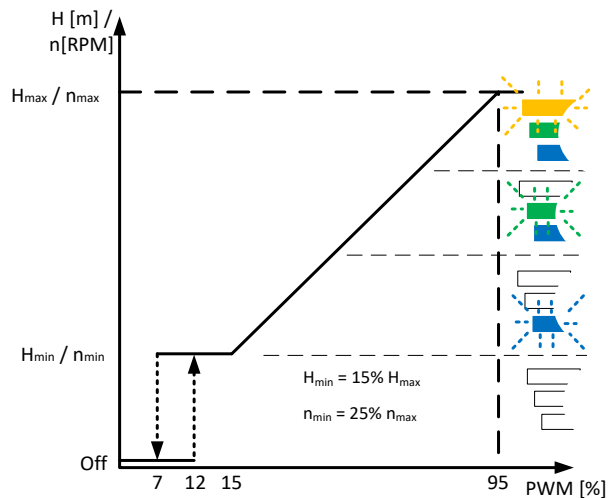

1.7.4 PWM OUTPUT

PWM output signals flow and error information from the pump according to the bottom table.

PWM - out	Status
0 %	PWM output interface in short circuit
2.5 %	Pump in standby and ready
5 %	Normal operation, no flow
5..75 %	Normal operation, flow indication
75 %	Normal operation, maximum nominal flow
80 %	Error is present, performance might be reduced
85 %	Error is present, pump is still functional, but might be stopped
90 %	Error is present, pump is stopped
95 %	Error is present, pump is stopped, permanent failure, will not restart
100%	PWM output interface is open circuit or pump is not powered

1.7.4.1 PWM SPECIFICATIONS

Technical data	PWM input	PWM output
PWM frequency	100 Hz -10000 Hz	75 Hz (± 1 Hz)
Maximum voltage	+24 V	+24 V
Input voltage for logic 1 at I_h	> 2,8 V	0 – 24 V
Input voltage for logic 0 at I_h	$\leq 1,2$ V	<1 V - 2 mA
Input current I_h	5 mA (4-7 mA)	<5 mA
PWM range	0 – 100%	0 – 100%
Signal polarity	Fiksna	Fiksna
Length of input cable	< 3 m	< 3 m
Isolation of input cable	SELV	SELV
Cross-section of cable	$\geq 0,25$ mm ²	$\geq 0,25$ mm ²

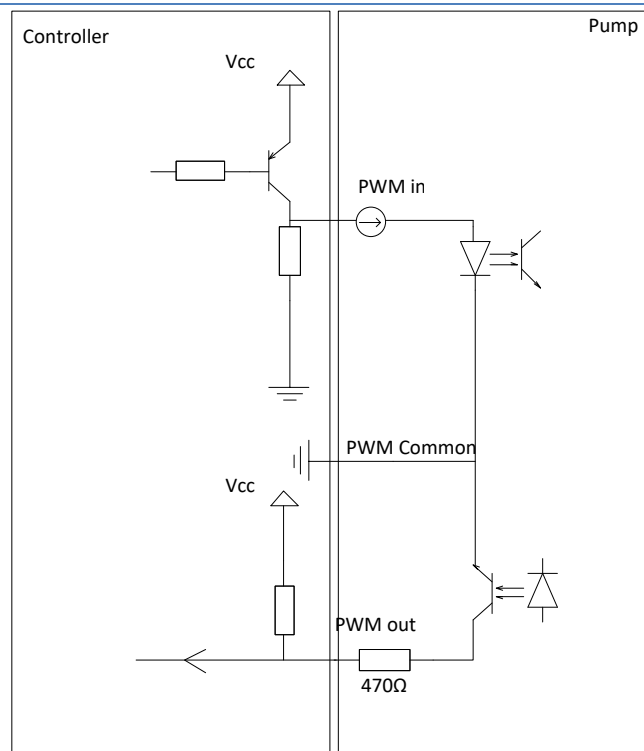

1.8 SPECIAL VERSIONS

1.8.1 L VERSION

Pumps have RPM_{min} - 5 % RPM_{max} , instead of 25 % RPM_{max}

Type	L version - RPM_{MIN}	Standard - RPM_{MIN}	RPM_{MAKS}
NMT NEO XX/30	170	850	3400
NMT NEO XX/40	200	1000	4000
NMT NEO XX/50	205	1025	4100
NMT NEO XX/60	240	1200	4800
NMT NEO XX/70	260	1300	5200
NMT NEO XX/80	280	1400	5600
NMT NEO XX/85	285	1425	5700
NMT NEO XX/90	290	1450	5800
NMT NEO XX/100	310	1550	6200
NMT NEO HF XX/100	315	1575	6300
NMT NEO HF XX/120	335	1675	6700
NMT NEO UHF XX/80	300	1500	6000
NMT NEO UHF XX/120	355	1775	7100

1.9 ORIENTATION

D Down (standard) - 0°

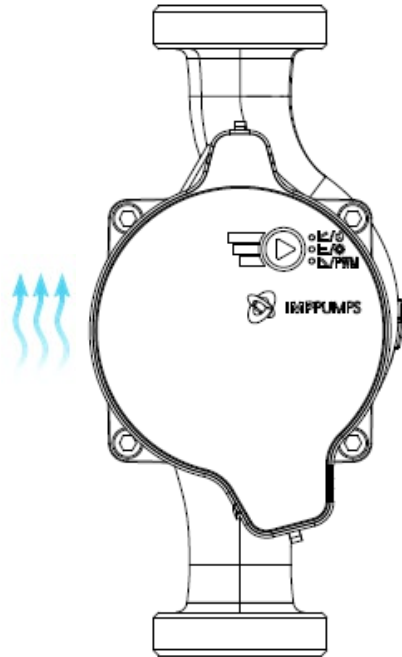

L

Left - 270°

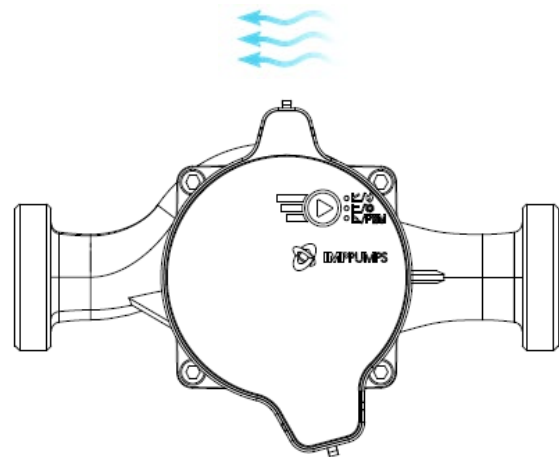

U Up - 180°

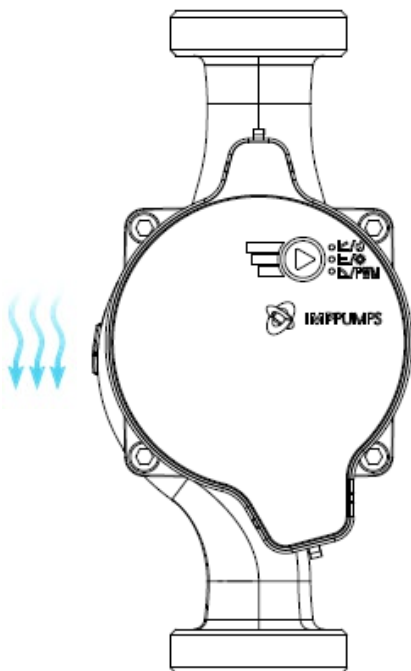

R

Right - 90°

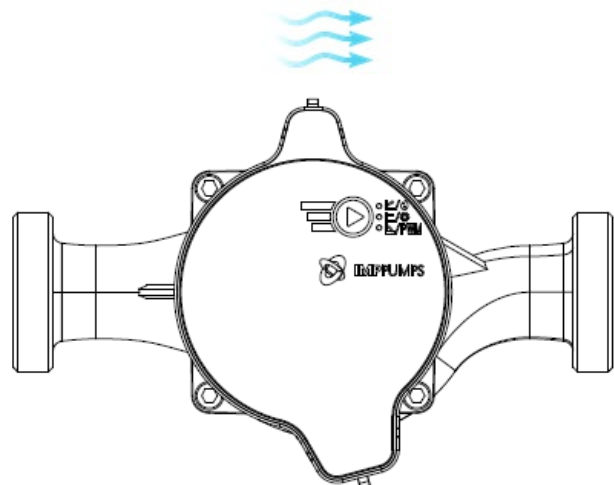

1.10 POWER CABLE

1.10.1 STRAIGHT CONNECTOR

Code	L	Order code	Cable type	Connector type
PCS050	50 cm	5000940	3G0,75 H03V2V2-F IDC	TE SuperSeal, straight
PCS100	100 cm	5000941	105°C NE Ø 5,7 (Blue,	
PCS150	150 cm	5000942	Brown, Yellow/Green)	
PCS200	200 cm	5000943		

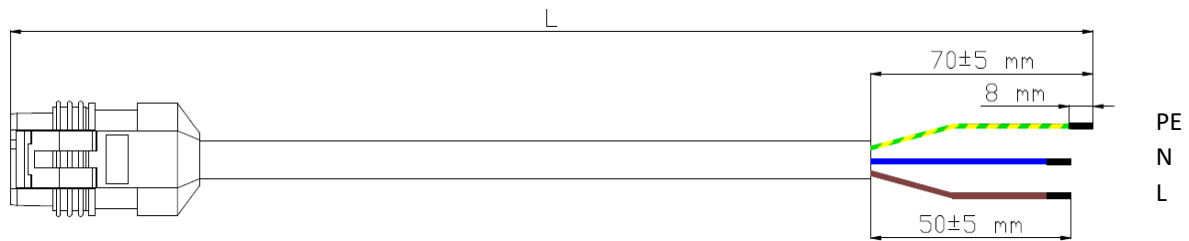

1.10.2 ANGLED CONNECTOR

Code	L	Order code	Cable type	Connector type
PCA050	50 cm	5000944	3G0,75 H03V2V2-F IDC	TE SuperSeal, angled
PCA100	100 cm	5000945	105°C NE Ø 5,7 (Blue,	
PCA150	150 cm	5000946	Brown, Yellow/Green)	
PCA200	200 cm	5000947		

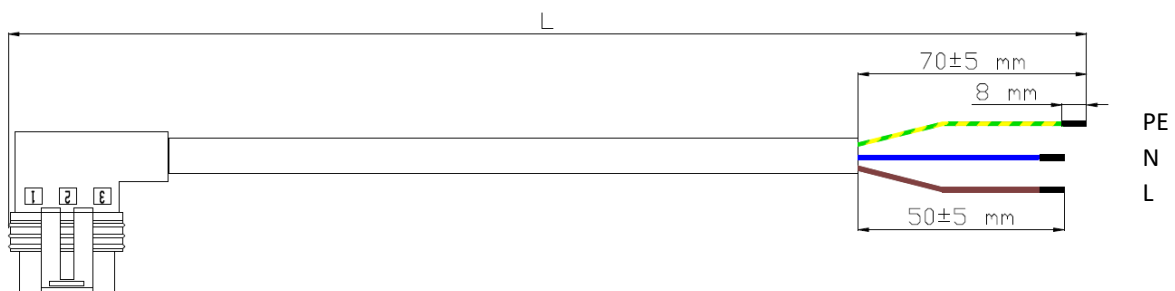

1.11 DATA CABLE

1.11.1 STRAIGHT CONNECTOR

Code	L	Order code	Cable type	Connector type
DCS050	50 cm	5000948	TE MiniSS 3X0,35	TE Mini
DCS100	100 cm	5000949	03V2V2-F IDC 105° NE Ø	SuperSeal,
DCS150	150 cm	5000950	4,4 (Blue, Brown, Black)	straight
DCS200	200 cm	5000951		

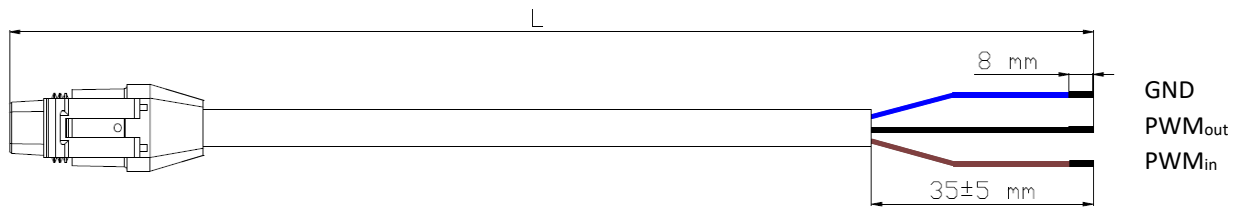

1.11.2 ANGLED CONNECTOR

Code	L	Order code	Cable type	Connector type
DCA050	50 cm	5000952	TE MiniSS 3X0,35 03V2V2-	TE Mini
DCA100	100 cm	5000953	F IDC 105° NE Ø 4,4 (Blue,	SuperSeal,
DCA150	150 cm	5000954	Brown, Black)	angled
DCA200	200 cm	5000955		

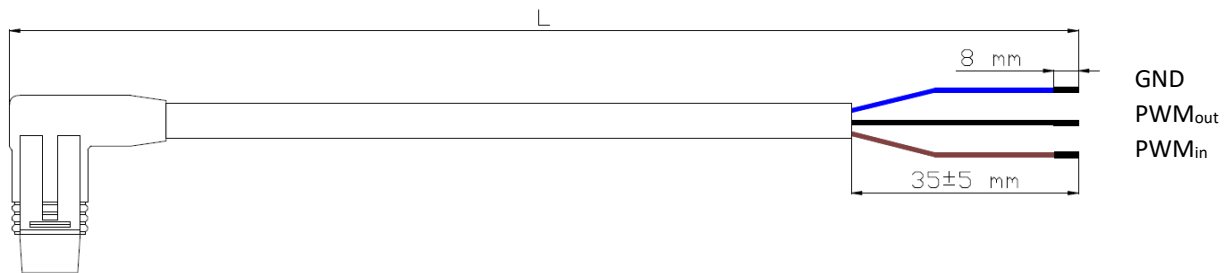

2 PUMP CURVES

2.1 NMT NEO PWM/SOL/HEAT

2.1.1 3M

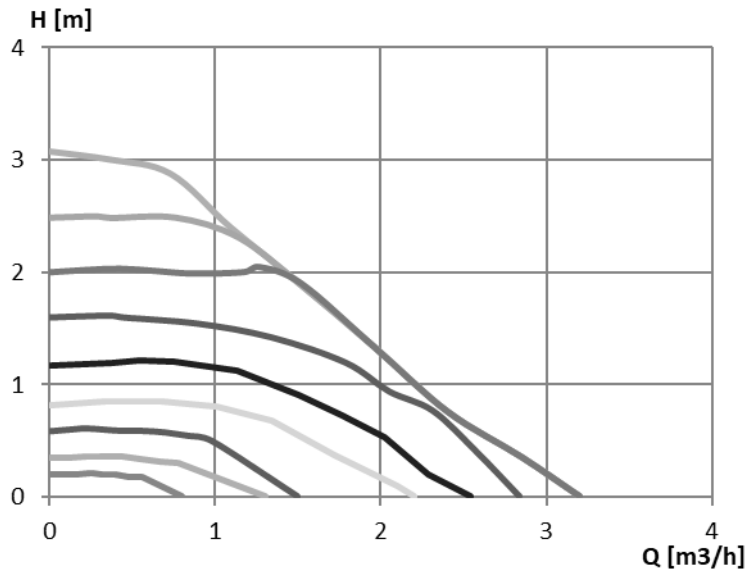

PWM speed		Head at closed valve [m]
Heat	Sol	
5%	95%	3
15%	85%	2,5
25%	75%	2
35%	65%	1,6
45%	55%	1,2
55%	45%	0,8
65%	35%	0,6
75%	25%	0,4
85%	12,5%	0,2

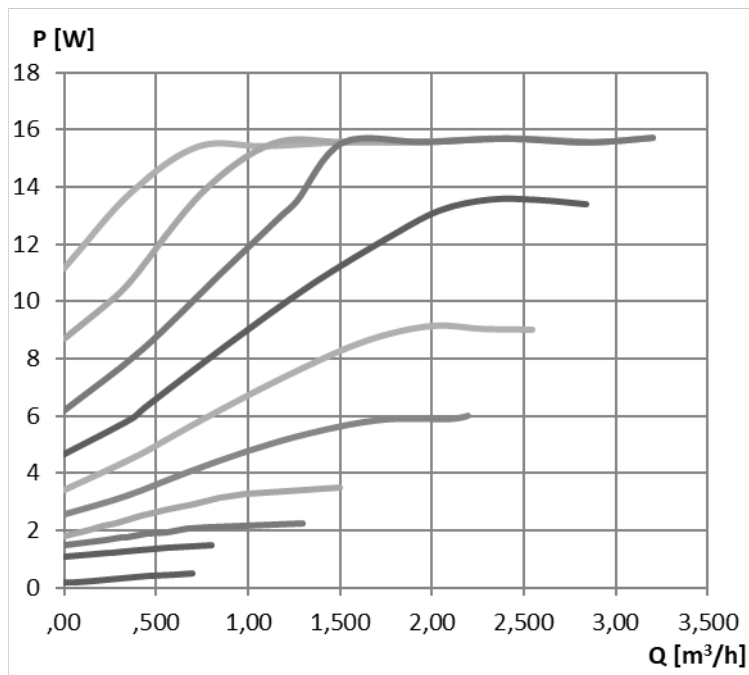

2.1.2 4M

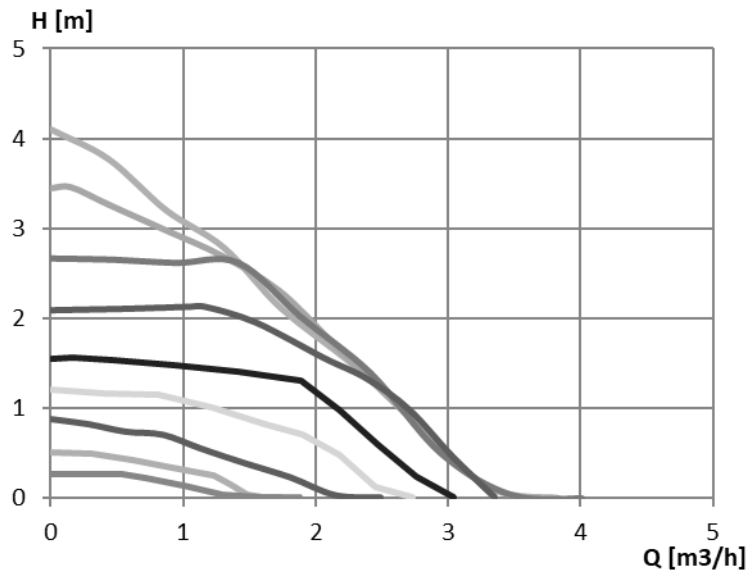

PWM speed		Head at closed valve [m]
Heat	Sol	
5%	95%	4
15%	85%	3,5
25%	75%	2,7
35%	65%	2,1
45%	55%	1,6
55%	45%	1,2
65%	35%	0,9
75%	25%	0,5
85%	12,5%	0,3

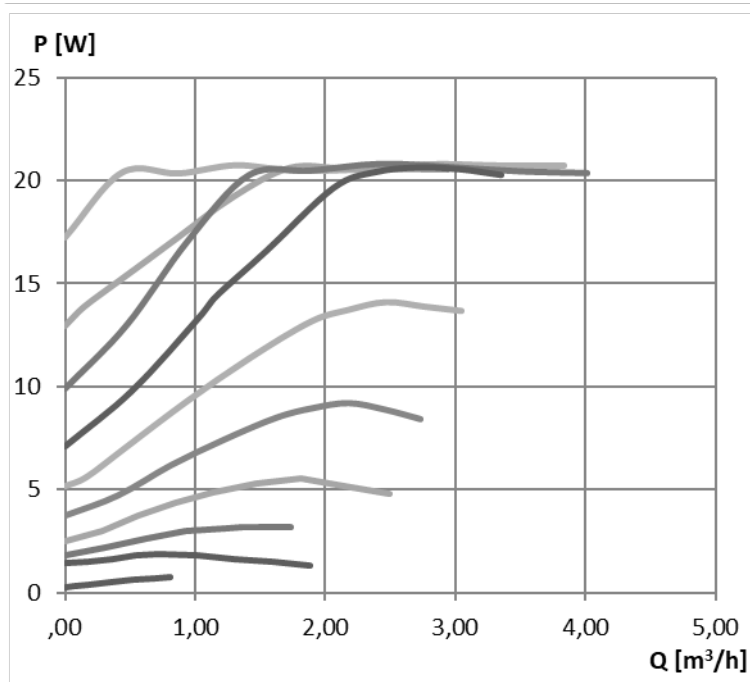

2.1.3 5M

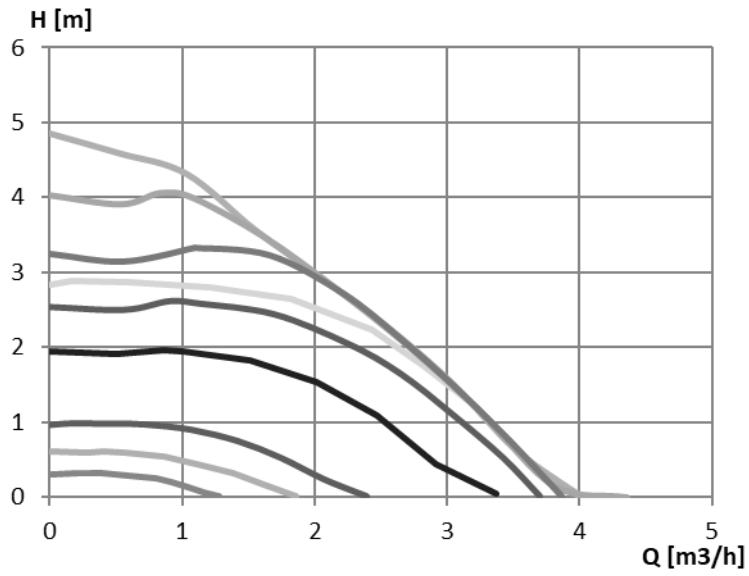

PWM speed		Head at closed valve [m]
Heat	Sol	
5%	95%	5
15%	85%	4,1
25%	75%	3,3
35%	65%	2,8
45%	55%	2,5
55%	45%	1,9
65%	35%	1
75%	25%	0,6
85%	12,5%	0,3

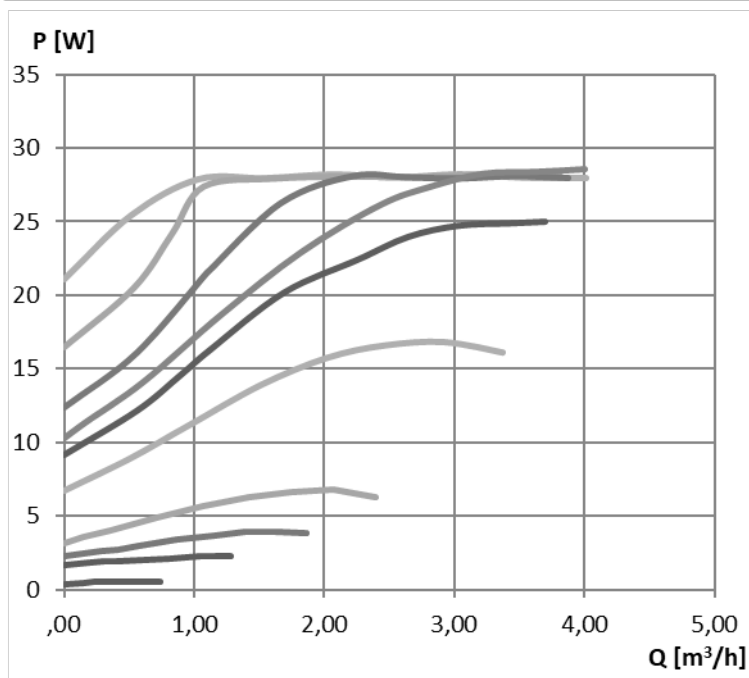

2.1.4 6M

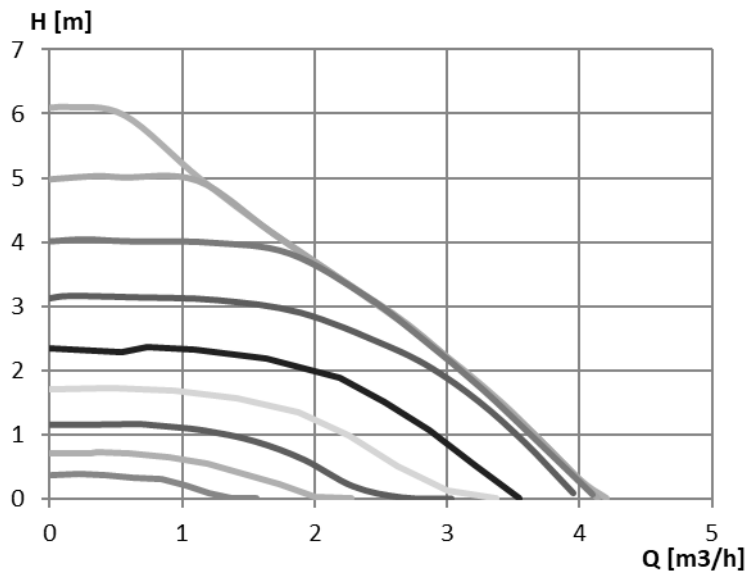

PWM speed		Head at closed valve [m]
Heat	Sol	
5%	95%	6
15%	85%	5
25%	75%	4
35%	65%	3,1
45%	55%	2,3
55%	45%	1,7
65%	35%	1,1
75%	25%	0,77
85%	12,5%	0,4

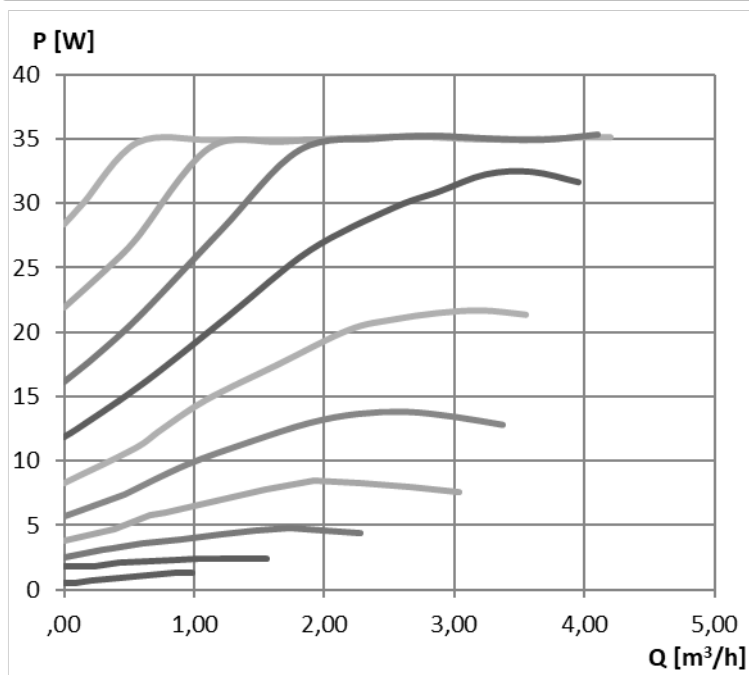

2.1.5 7M

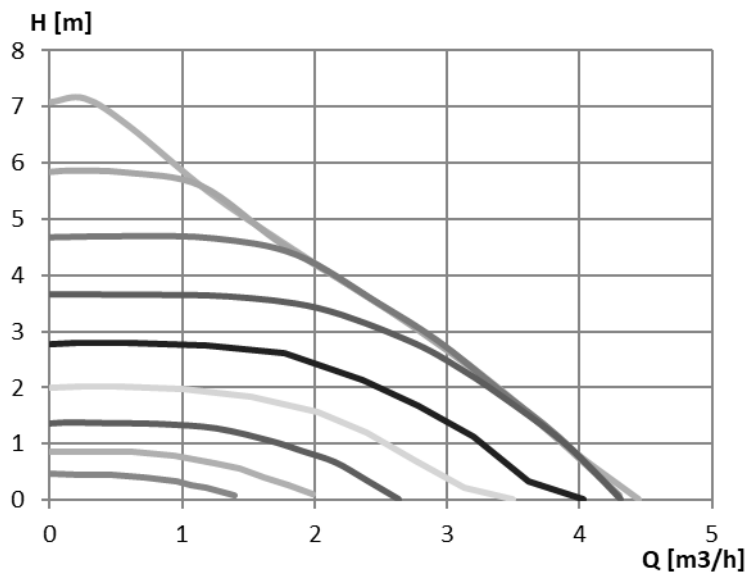

PWM speed		Head at closed valve [m]
Heat	Sol	
5%	95%	7
15%	85%	5,9
25%	75%	4,7
35%	65%	3,7
45%	55%	2,8
55%	45%	2
65%	35%	1,4
75%	25%	0,9
85%	12,5%	0,5

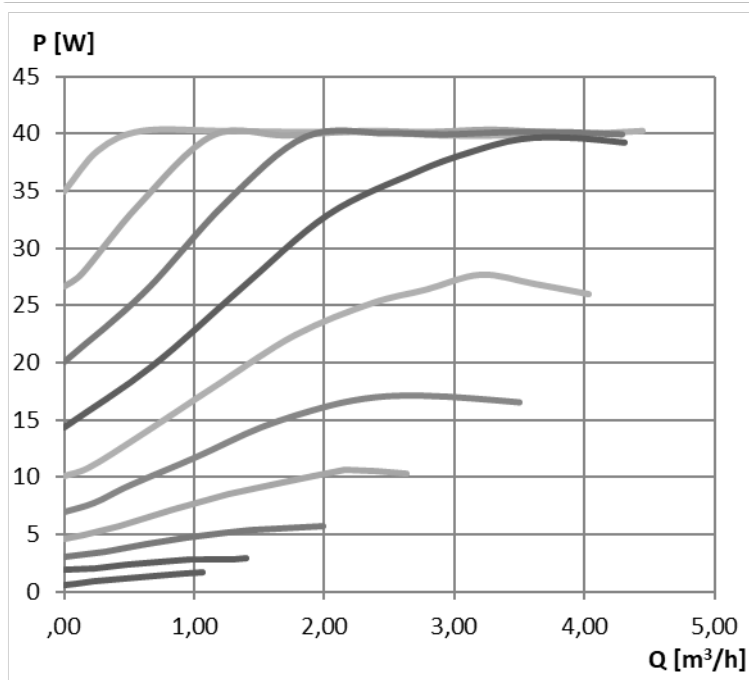

2.1.6 8M

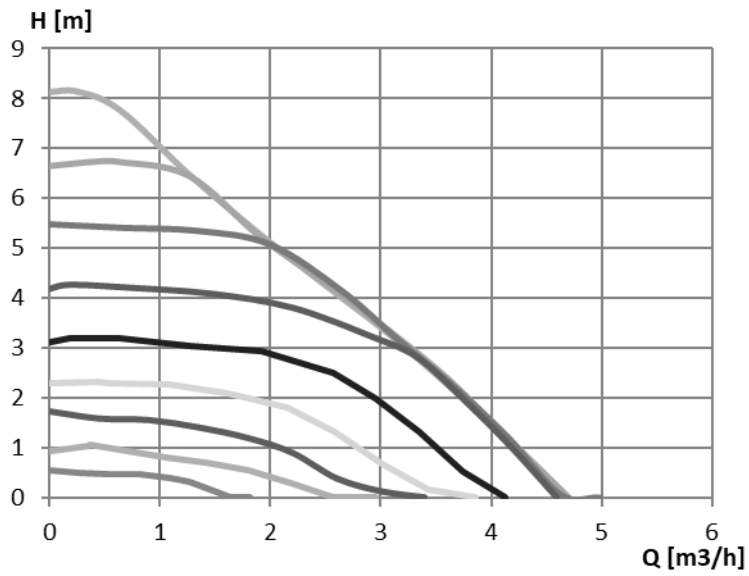

PWM speed		Head at closed valve [m]
Heat	Sol	
5%	95%	8
15%	85%	6,6
25%	75%	5,5
35%	65%	4,2
45%	55%	3,1
55%	45%	2,3
65%	35%	1,7
75%	25%	1
85%	12,5%	0,6

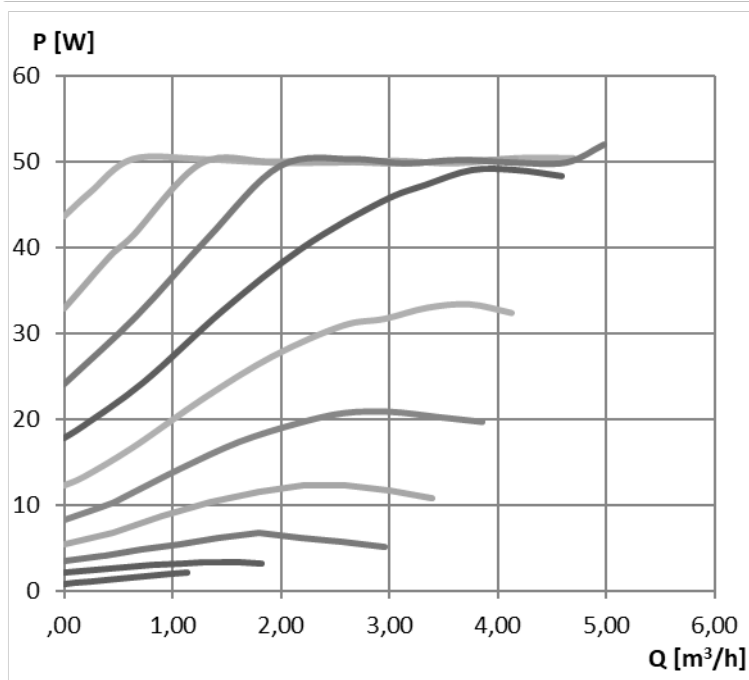

2.1.7 8,5M

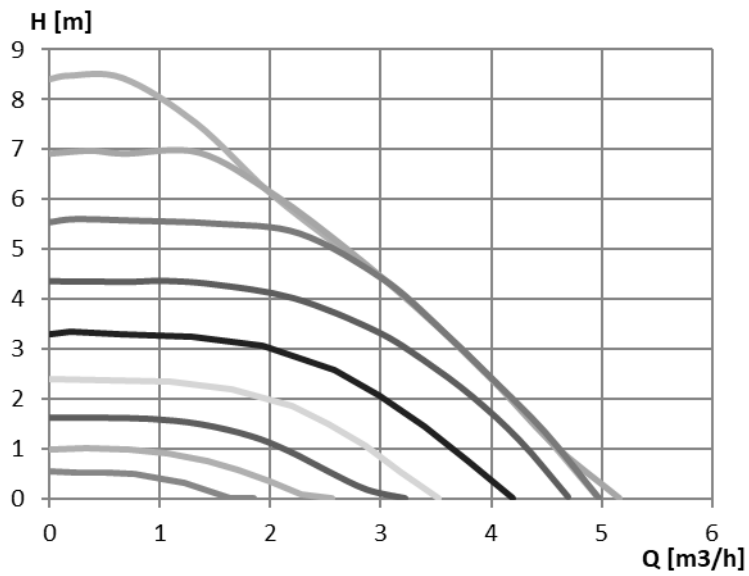

PWM speed		Head at closed valve [m]
Heat	Sol	
5%	95%	8,5
15%	85%	6,9
25%	75%	5,6
35%	65%	4,4
45%	55%	3,3
55%	45%	2,4
65%	35%	1,7
75%	25%	1
85%	12,5%	0,6

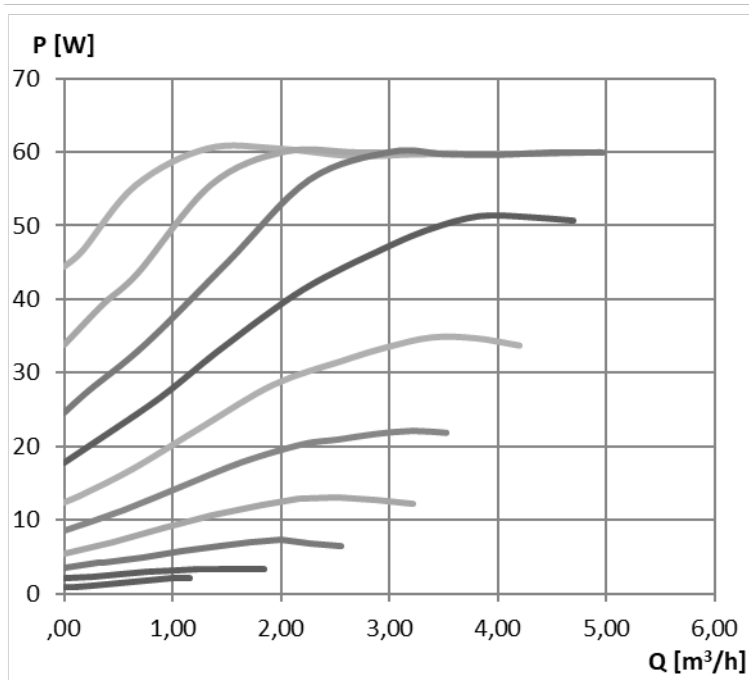

2.1.8 9M

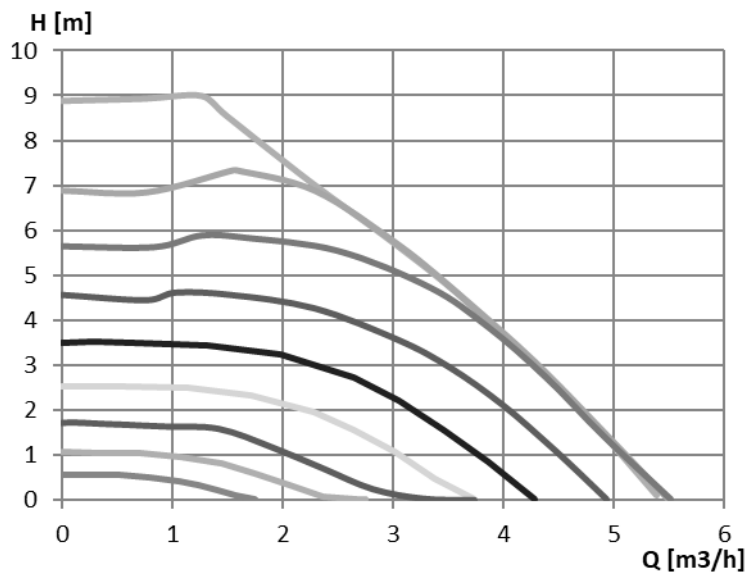

PWM speed		Head at closed valve [m]
Heat	Sol	
5%	95%	9
15%	85%	6,9
25%	75%	5,6
35%	65%	4,6
45%	55%	3,5
55%	45%	2,5
65%	35%	1,7
75%	25%	1
85%	12,5%	0,6

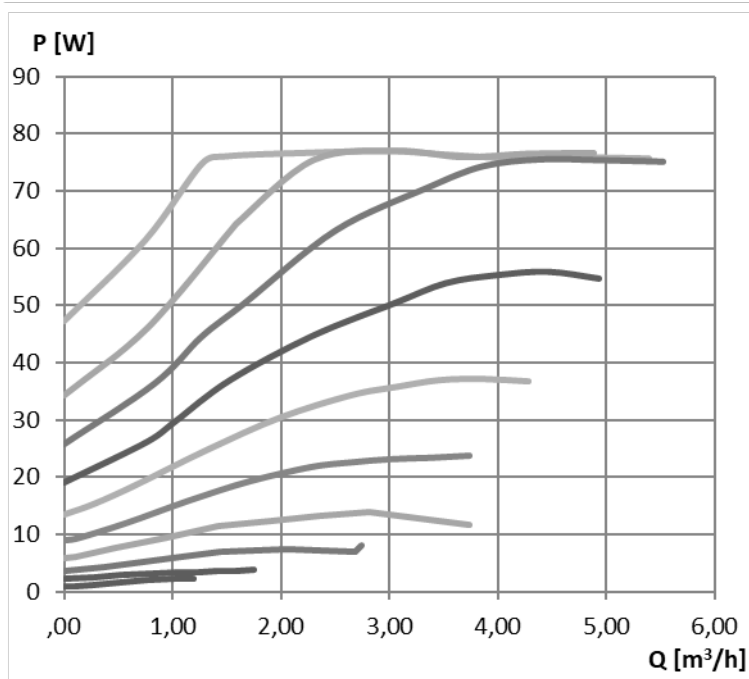

2.1.9 10M

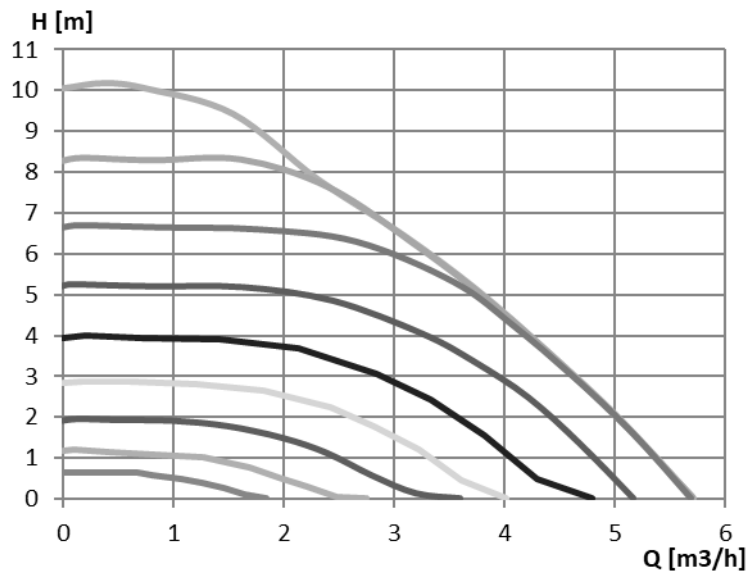

PWM hitrost		PWM speed
Heat	Sol	
5%	95%	10
15%	85%	8,3
25%	75%	6,6
35%	65%	5,2
45%	55%	4
55%	45%	2,8
65%	35%	1,9
75%	25%	1,2
85%	12,5%	0,7

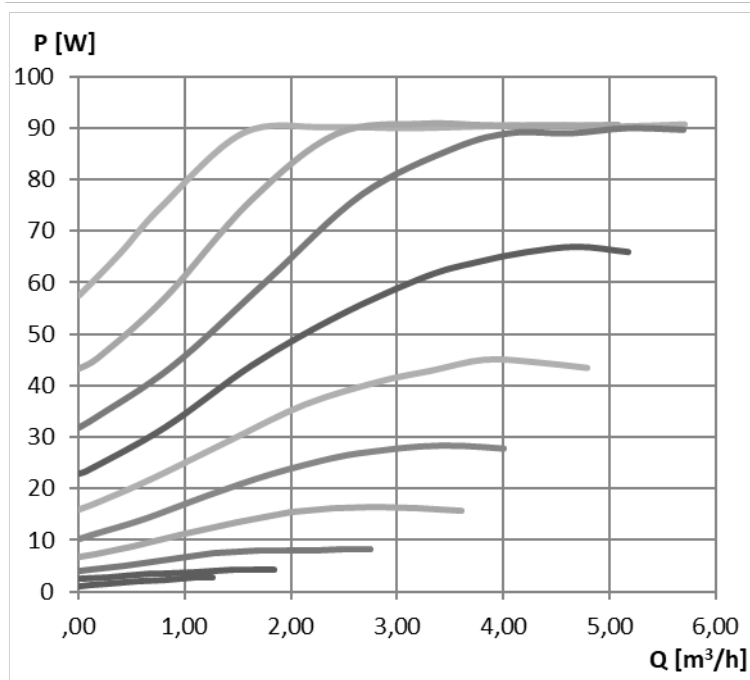

2.2 NEO HF PWM/SOL/HEAT

2.2.1 10M

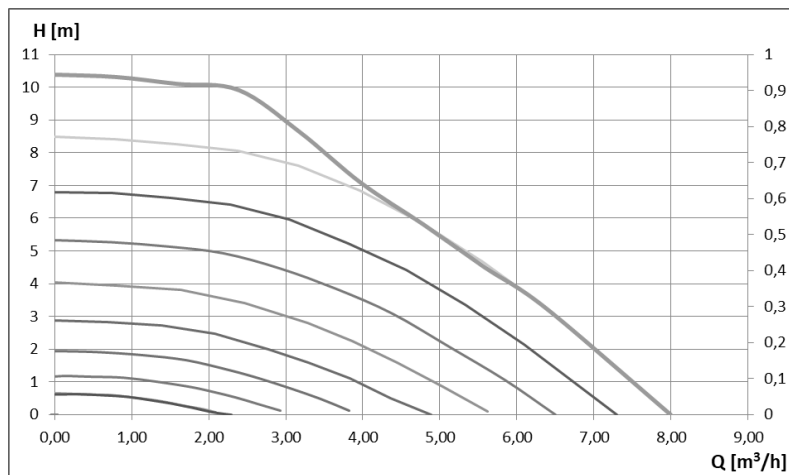

PWM hitrost Heat	Sol	Tlak pri zaprtem ventilu [m]
5%	95%	10,4
15%	85%	8,5
25%	75%	6,8
35%	65%	5,3
45%	55%	4
55%	45%	2,8
65%	35%	1,9
75%	25%	1,7
85%	12,5%	0,6

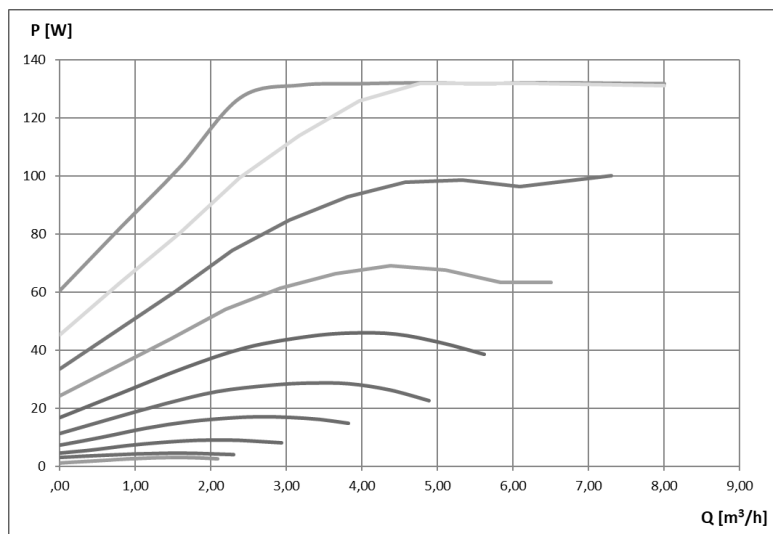

2.2.2 12M

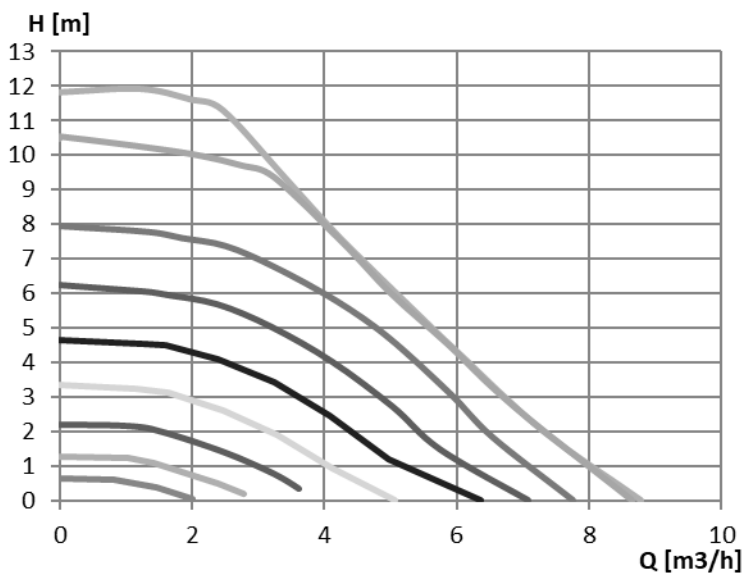

PWM speed		Head at closed valve [m]
Heat	Sol	
5%	95%	12
15%	85%	10,5
25%	75%	8
35%	65%	6,2
45%	55%	4,6
55%	45%	3,3
65%	35%	2,2
75%	25%	1,3
85%	12,5%	0,7

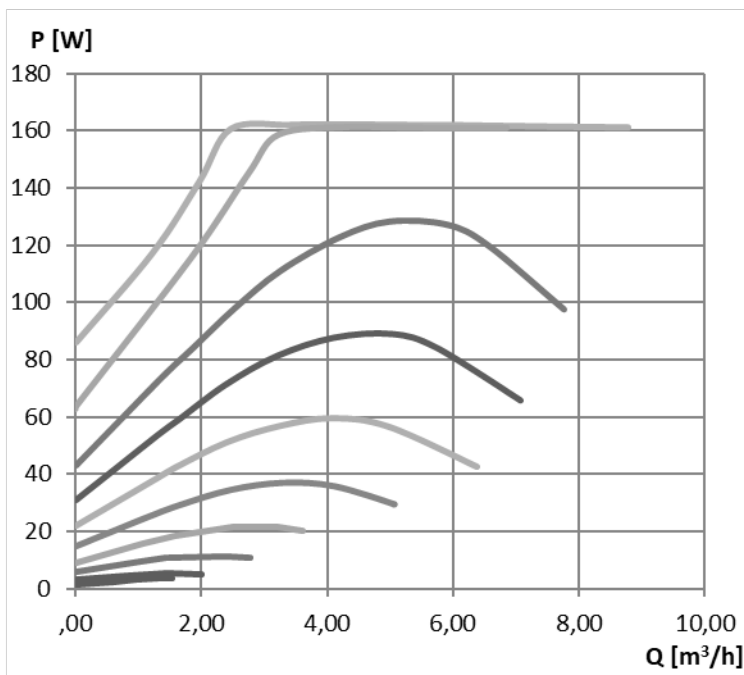

2.3 NMT NEO UHF PWM/SOL/HEAT

2.3.1 8M

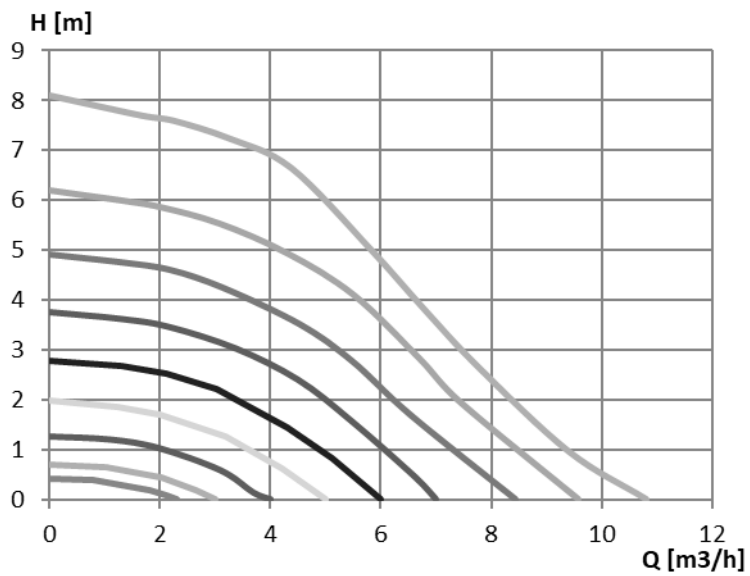

PWM speed		Head at closed valve [m]
Heat	Sol	
5%	95%	8
15%	85%	6,2
25%	75%	4,9
35%	65%	3,7
45%	55%	2,8
55%	45%	2
65%	35%	1,2
75%	25%	0,7
85%	12,5%	0,4

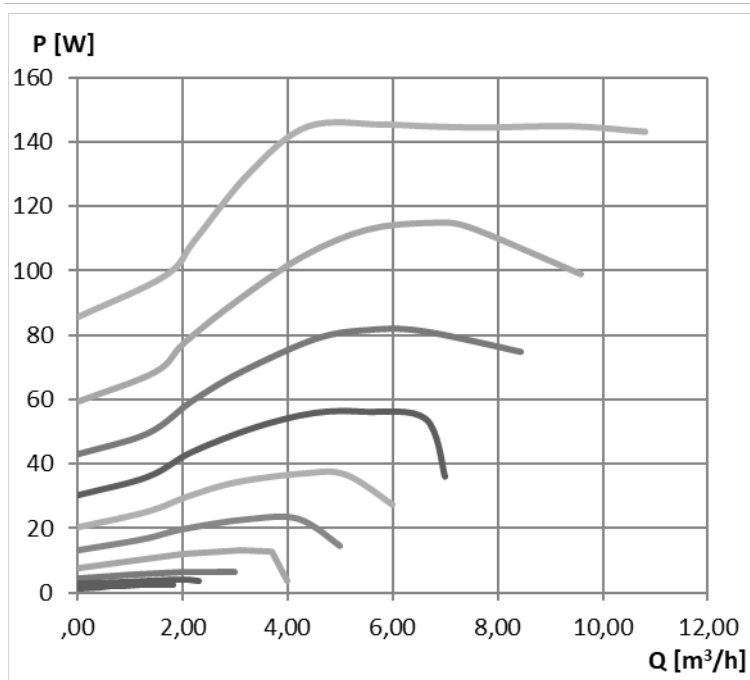

2.3.2 12M

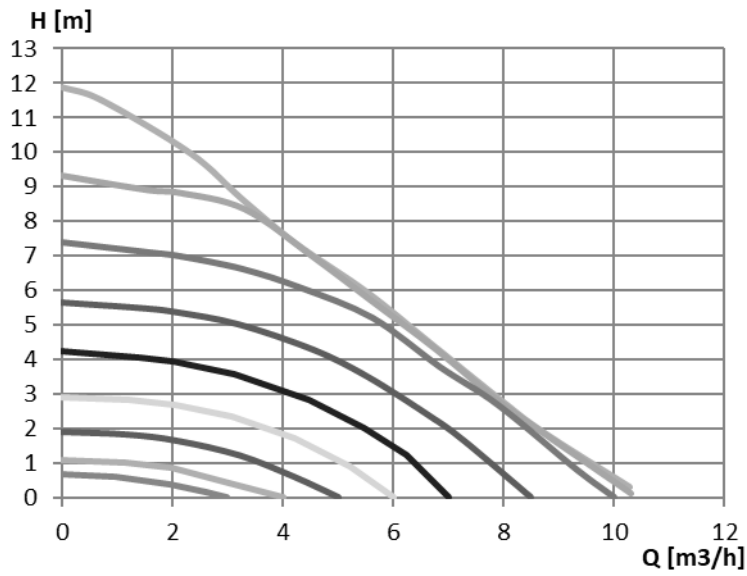

PWM speed		Head at closed valve [m]
Heat	Sol	
5%	95%	12
15%	85%	10,55
25%	75%	8
35%	65%	6,2
45%	55%	4,7
55%	45%	3,3
65%	35%	2,2
75%	25%	1,3
85%	12,5%	0,7

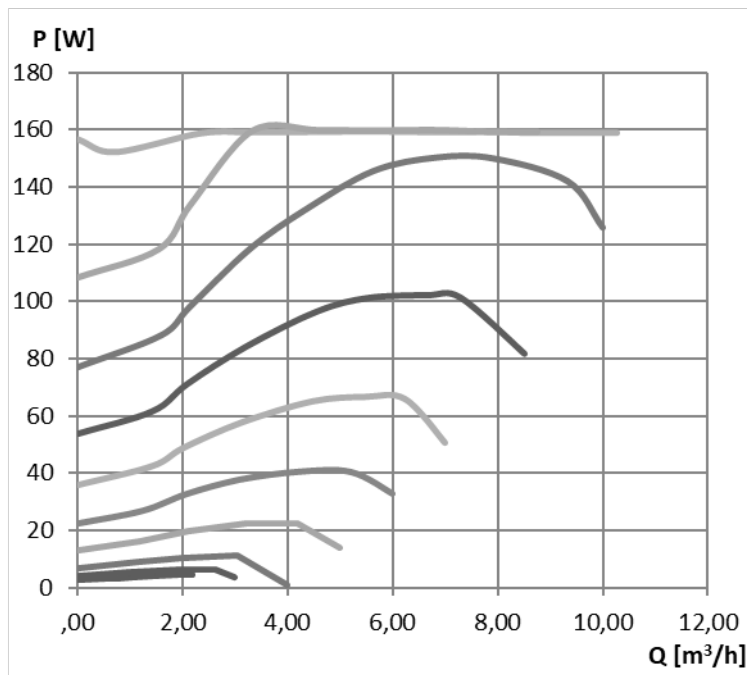

3 DIMENSIONS

3.1 NEO

3.1.1 15-130

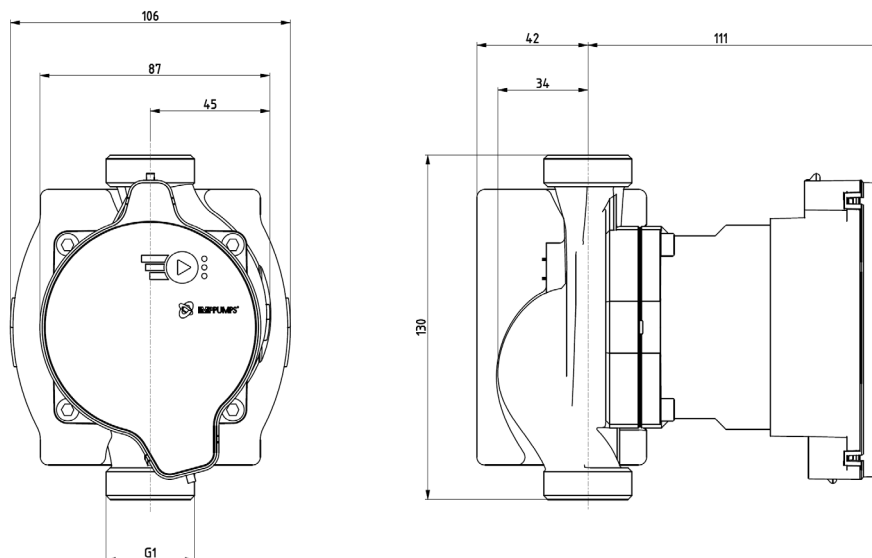

Pump type	G	L [mm]	Weight [kg]
15-130	G 1	130	1,47

3.1.2 20-130

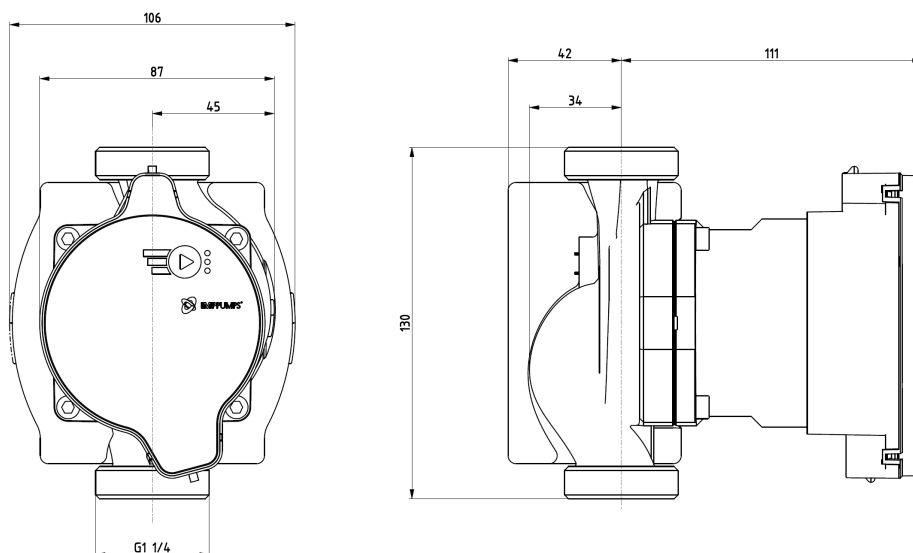

Pump type	G	L [mm]	Weight [kg]
20-130	G 1 ¼	130	1,56

3.1.3 25-130

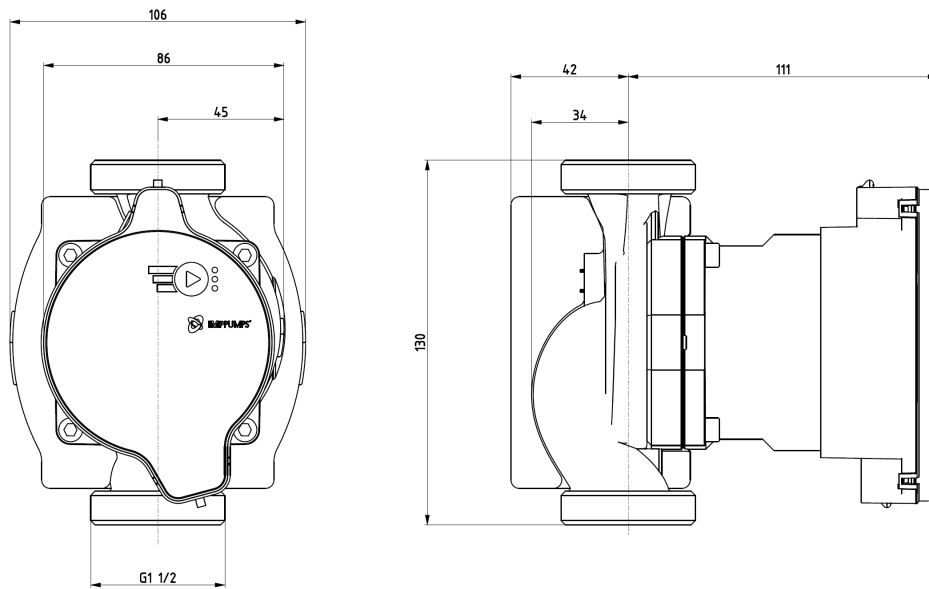

Pump type	G	L [mm]	Weight [kg]
25-130	G 1 ½	130	1,66

3.1.4 20-180

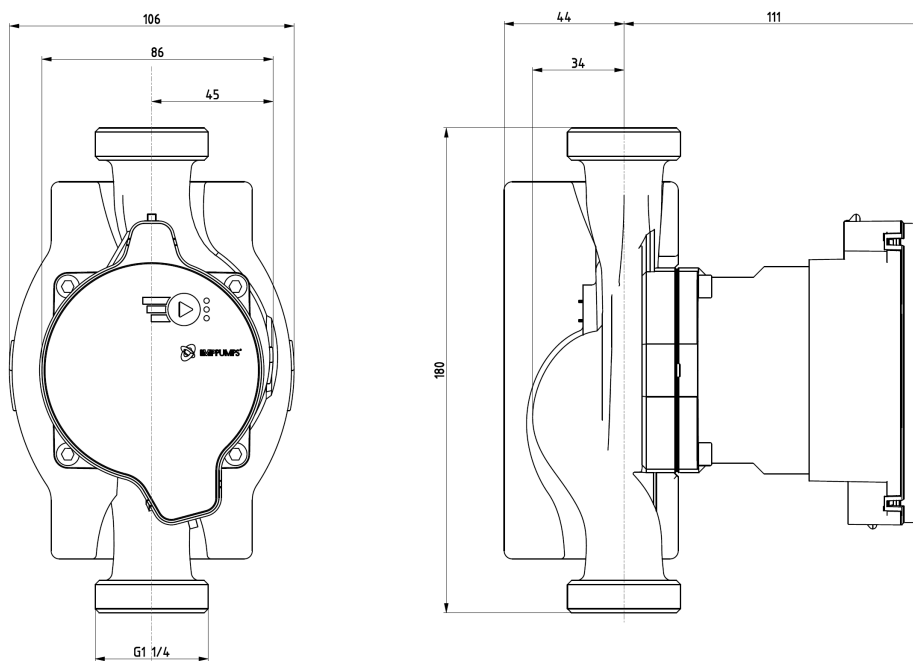

Pump type	G	L [mm]	Weight [kg]
20-180	G 1 ¼	180	1,67

3.1.5 25-180

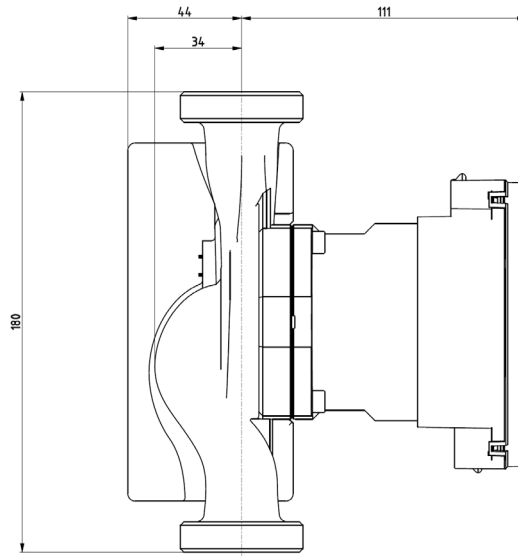
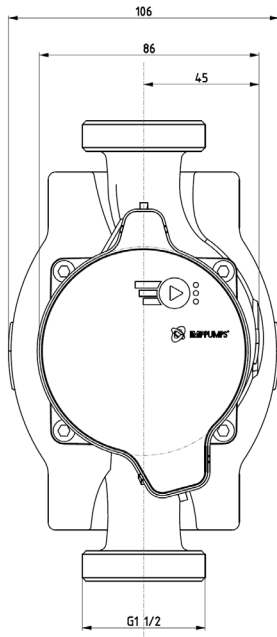

Pump type	G	L [mm]	Weight [kg]
25-180	G 1 ½	180	1,74

3.1.6 32-180

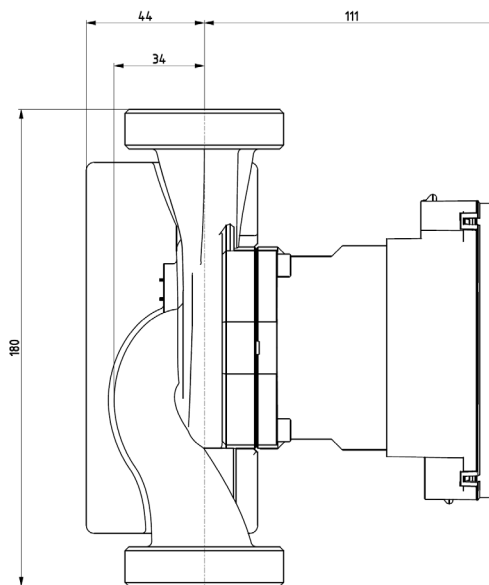
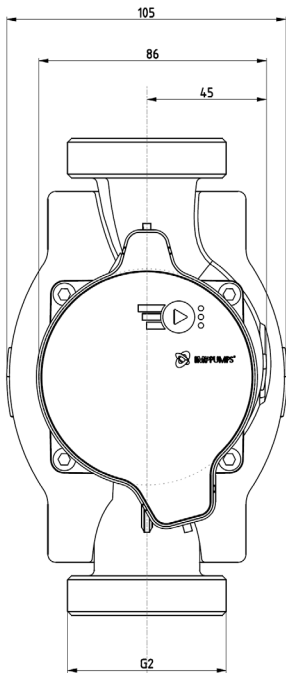

Pump type	G	L [mm]	Weight [kg]
32-180	G 2	180	1,94

3.2 NMT NEO HF

3.2.1 15-130

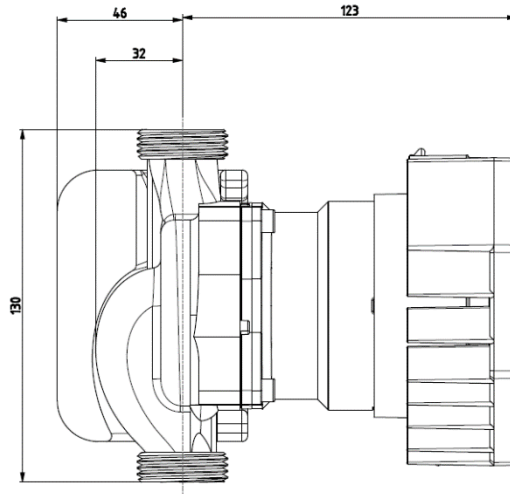
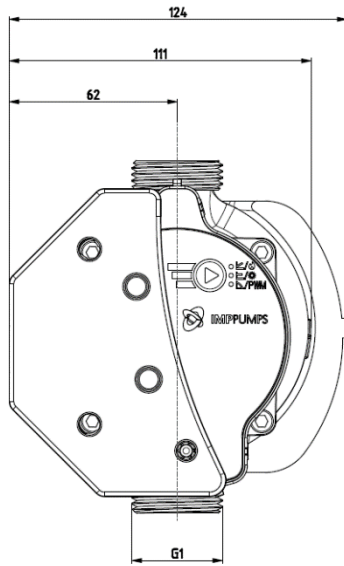

Pump type	G	L [mm]	Weight [kg]
15-130	G 1	130	1,97

3.2.2 25-130

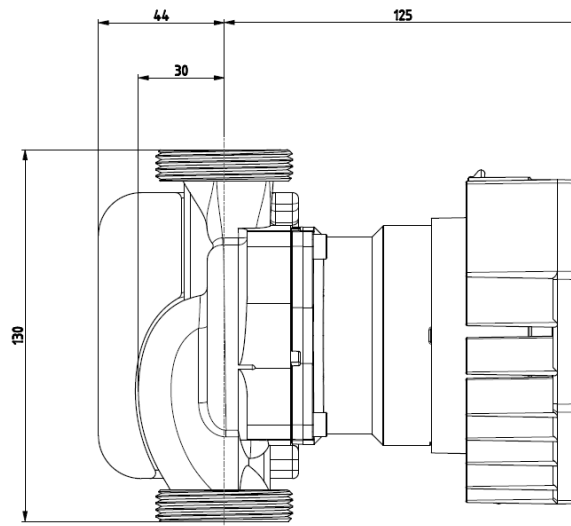
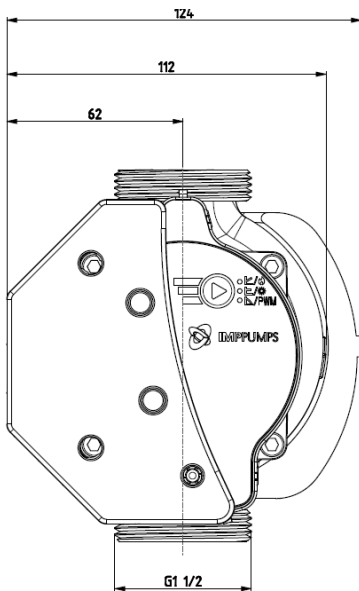

Pump type	G	L [mm]	Weight [kg]
25-130	G 1 ½	130	2,11

3.2.3 25-180

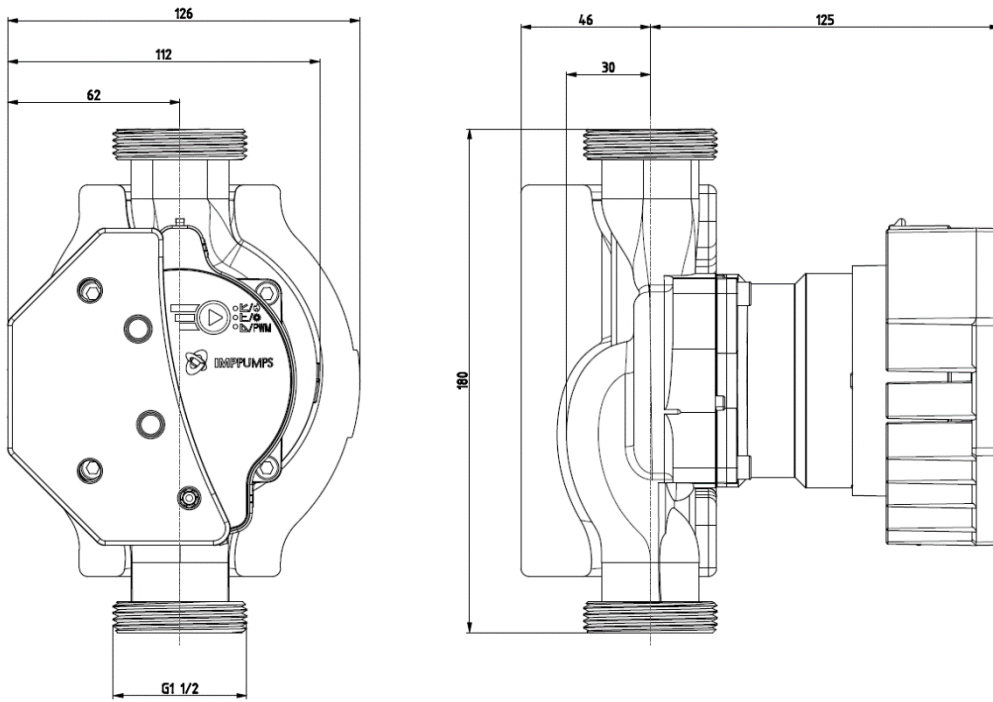

Pump type	G	L [mm]	Weight [kg]
25-180	G 1 ½	180	2,26

3.2.4 32-180

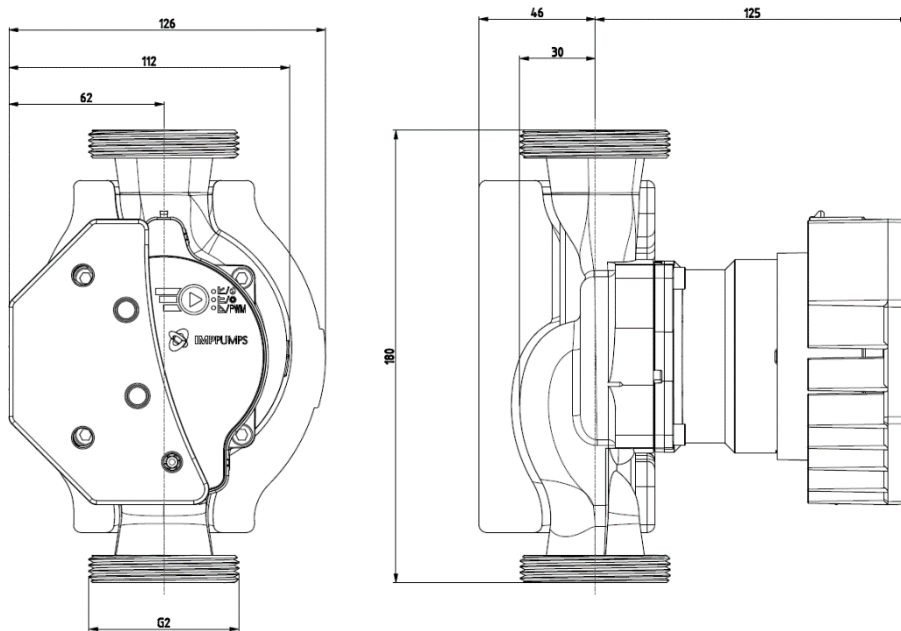

Pump type	G	L [mm]	Weight [kg]
32-180	G 2	180	2,38

3.3 NMT NEO UHF

3.3.1 25-180

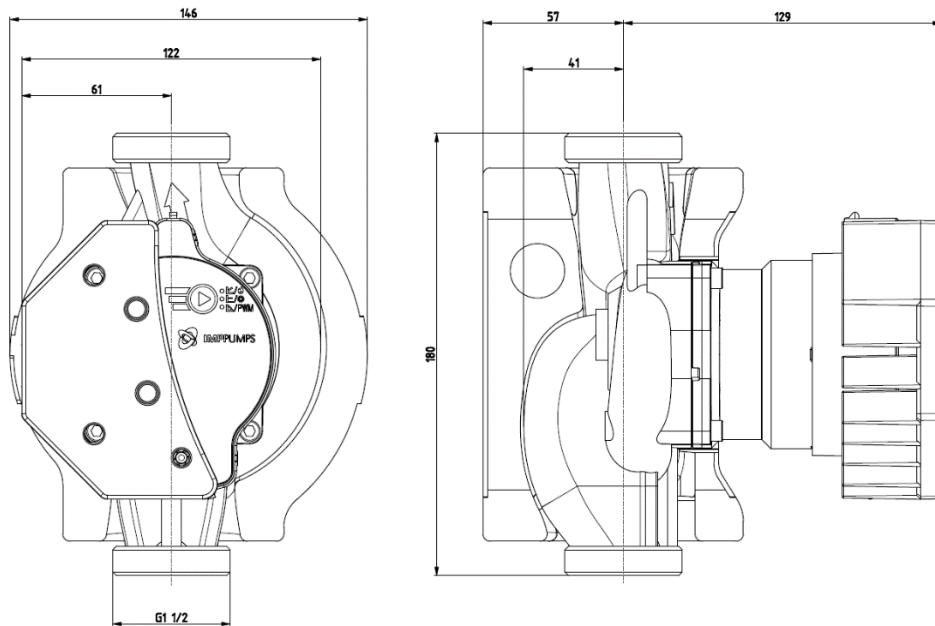

Pump type	G	L [mm]	Weight [kg]
25-180	G 2 ½	180	2,83

3.3.2 32-180

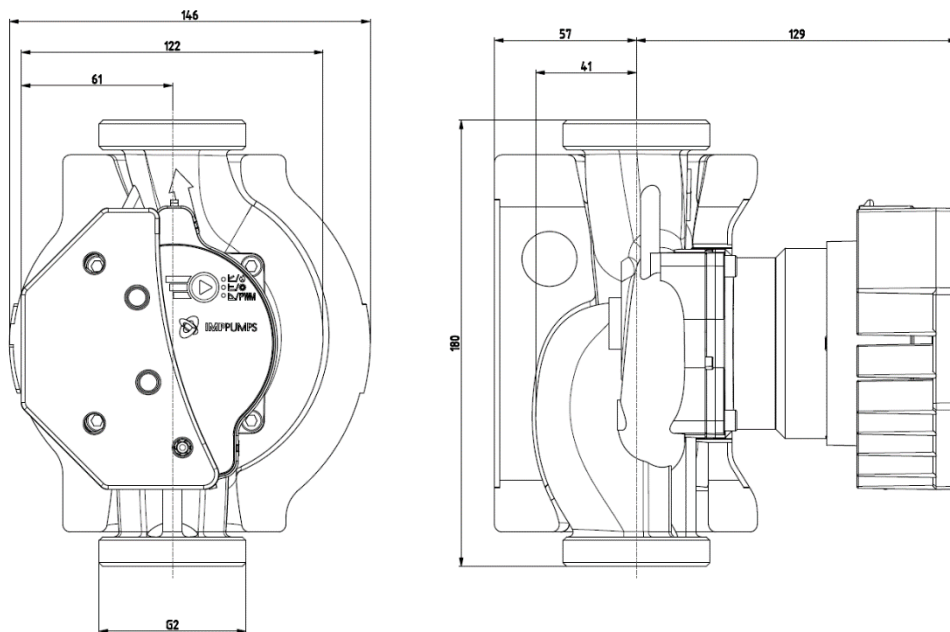

Pump type	G	L [mm]	Weight [kg]
32-180	G 2	180	2,96